

General Specification of 6 Wheels Truck

Model: PKB214 Turbo/Intercool 216 PS



Engine

Manufacturer and Model	Nissan Diesel Motor Model FE6TA-21
Type	Diesel engine 4 cycle, 6 in-line cylinders, Turbo Intercool, Direct-injection, Water cooled
Total Piston Displacement	6,925 cc
Bore x Stroke	108 x 126 mm.
Max.Output	JIS Gross 216 PS at 2,800 rpm. ECE Net. 157 kW at 2,800 rpm.
Max.Torque	JIS Gross 61 kg-m at 1,800 rpm. ECE Net. 588 N-m at 1,800 rpm.
Max.Speed	3,200 rpm.
Compression Ratio	17.5:1
Governor	RLD-J All speed control
Lubrication	Forced feed by gear pump
Steering	Recirculating ball screw type with hydraulic power assistance, adjustable, tilt-telescopic

Brake and Others

Service Brake	Air over hydraulic, Dual line system
Parking Brake (Hand Brake)	Mechanically operated, Internal expanding, Acting on drum at rear of gearbox
Retarder	Exhaust Brake
Fuel Tank	200 liters
Wheel and tire	Rim 6.50T x 20 Tire 9.00 x 20-14PR

Gear Box (Transmission)

Manufacturer and Model	Nissan Diesel Motor Model MLS61 B
Type	6 Forward speeds, 1 Reverse, Synchromesh on 2nd to 6th with overdrive, Constantmesh on 1st and reverse gear
Gear Ratios	1) 6.718 2) 4.031 3) 2.303 4) 1.443 5) 1.000 6) 0.740 Reverse 6.121
Final Reduction Gear Ratio	Single reduction hypoid gear 6.500
Clutch	Dry single plate, Hydraulically operated clutch release mechanism with air assisted booster

Electrical Equipment

Electrical system	Head light 2 lamps, Clearance lights, Turn signal light, Back up light, License plate light, Stop/tail lights, Hazard warning flasher, Fog lights, Interior light, Reading light and Engine start switch
Battery	12 Volt x 2, 65 Ah.
Starting Motor	24 Volt, 5 kW
Alternator	24 Volt-40 amp.

Cab and Standard Equipment

Type	Steel weld construction, Tilt cab with openable front grill
Windshield	Multi-layer safety glass, Laminated type
Rear View Mirrors	Large size with under view mirrors
Windshield Wiper	Triple, Intermittent 3-speed electric wipers with windshield washer
Instrument Panel	Speedometer, Tachometer, Odometer, Air pressure gauge, Water temperature gauge, Fuel level gauge
Warning Lights	Low engine oil pressure indicator, Turn signal indicator, Hazard warning flasher, Head light high beam indicator, Battery charge warning indicator, Parking brake indicator, Exhaust brake indicator, Engine coolant over-heating, Low air pressure indicator, Low brake fluid level indicator, Cab lock indicator, Air filter clog indicator
Audible Equipment	Radio (AM-FM) - Cassette tape Digital system with speaker
Seats	Made of high quality vinyl, Adjustable back angle, Fore and aft position, Driver's weight adjustable suspension type
Safety Belt	3 points lock type for driver and assistance seat 2 points lock type for middle seat

Chassis

Frame	Channel (C section), Ladder type
Side Member Main Section	250 x 80 x 8 mm. (Height x Width x Thickness)
Front Axle	Reverse Elliot I-Beam
Rear Axle	Fully floating banjo type, Tandem drive axles with DF lock
Suspensions	Front Semi-elliptic leaf springs with shockabsorbers Rear Semi-elliptic leaf springs with helper leaf springs

Registered Truck Model: PKB214EHRA
PKB214GHRA
PKB214NHRA

Special Equipment: Wind Deflector and PTO are the standard equipment.

Remarks: All details and pictures which shown in this leaflet may be option equipment and different from standard chassis. Nissan Diesel (Thailand) reserves the right to change any specification without notice.

Safety glass, 2 Layer,
Laminated type,
Sun filter coating



JOB BUILT-UP DURABLY & RELIABLY
Nissan Diesel (Thailand) Co., Ltd.

59 Moo 1, Rangsit-Pathumthani Road, Bangkok, Muang District, Pathumthani 12000

Tel: 0-2567-2882, 0-2567-2888, Fax: 0-2567-2883-4, 0-2567-2886-7 <http://www.nissandiesel.co.th>



2 years guarantee, unlimited distance
refer to our guarantee's condition



PKB 216 PS

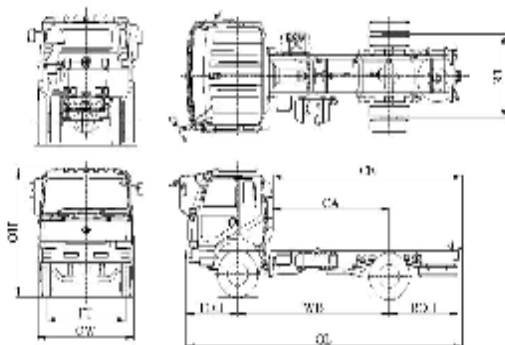

Performance	PKB214E	PKB214G	PKB214N
Maximum Speed (Km./Hr.)	116	116	116
Minimum Turning Radius (M.)	6.6	7.6	9.3
Gradeability (Tan θ)	0.425	0.425	0.425
at Gross Vehicle Weight (Kg.)	12,000	12,000	12,000

Weight	PKB214E	PKB214G	PKB214N
Chassis with cab (Kg.)	3,915	3,965	4,105
On front wheels (Kg.)	2,365	2,405	2,465
On rear wheels (Kg.)	1,550	1,560	1,640
Maximum GVW (Manufacturer)	14,200	14,200	14,200

General Dimension (MM.)

Model	WB	OL	OW	OH	FT	RT	CA	ROH	CE
PKB214E	3,750	6,830	2,375	2,705	1,960	1,800	2,875	1,700	4,575
PKB214G	4,400	7,730	2,375	2,705	1,960	1,800	3,525	1,950	5,475
PKB214N	5,550	9,530	2,375	2,705	1,960	1,800	4,675	2,600	7,275