

General Specification of 10 Wheels Truck

Model: CDA214 Turbo/Intercool 254 PS



Engine

Manufacturer and Model	Nissan Diesel Motor Model FE6TC-21	
Type	Diesel engine, 4 cycle, 6 in-line cylinders, Turbo Intercool, Direct-injection, Water cooled	
Total Piston Displacement	6,925 cc	
Bore x Stroke	108 x 126 mm.	
Max.Output	JIS Gross	254 PS at 2,800 rpm.
	ECE Net.	184 kW at 2,800 rpm.
Max.Torque	JIS Gross	69 kg-m at 1,800 rpm.
	ECE Net.	667 N-m at 1,800 rpm.
Max.Speed	3,000 rpm.	
Compression Ratio	18.5:1	
Governor	Electronic governor, model "RED III"	
Lubrication	Forced feed by gear pump	
Steering	Recirculating ball screw type with hydraulic power assistance, adjustable, tilt-telescopic	

Brake and Others

Service Brake	Air over hydraulic, Dual line system
Parking Brake (Hand Brake)	Mechanically operated, Internal expanding, Acting on drum at rear of gearbox
Retarder	Exhaust Brake
Fuel Tank	200 liters
Wheel and tire	Rim 7.00T x 20 Tire 9.00 x 20-14PR

Electrical Equipment

Electrical system	Head light 2 lamps, Clearance lights, Turn signal light, Back up light, License plate light, Stop/tail lights, Hazard warning flasher, Fog lights, Interior light, Reading light and Engine start switch
Battery	12 Volt x 2, 65 Ah.
Starting Motor	24 Volt, 5 kW
Alternator	24 Volt-40 amp.

Gear Box (Transmission)

Manufacturer and Model	Nissan Diesel Motor Model MPS62B	
Type	6 forward speeds, 1 reverse Synchromesh on 2nd to 6th with overdrive, Constantmesh on 1st and reverse gear.	
Gear Ratios	1)	7.027
	2)	4.277
	3)	2.493
	4)	1.500
	5)	1.000
	6)	0.780
	Reverse	7.038
Final Reduction Gear Ratio	Single reduction hypoid gear 6.166	
Clutch	Dry single plate, Hydraulically operated clutch release mechanism with air assisted booster	

Cab and Standard Equipment

Type	Steel weld construction, Tilt cab with openable front grill
Windshield	Multi-layer safety glass, Laminated type
Rear View Mirrors	Large size with under view mirrors
Windshield Wiper	Triple, Intermittent 3-speed electric wipers with windshield washer
Instrument Panel	Speedometer, Tachometer, Odometer, Air pressure gauge, Water temperature gauge, Fuel level gauge
Warning Lights	Low engine oil pressure indicator, Turn signal indicator, Hazard warning flasher, Head light high beam indicator, Battery charge warning indicator, Parking brake indicator, Exhaust brake indicator, Engine coolant over-heating, Low air pressure indicator, Low brake fluid level indicator, Cab lock indicator, Air filter clog indicator
Audible Equipment	Radio (AM-FM) - Cassette tape Digital system with speaker
Seats	Made of high quality vinyl, Adjustable back angle, Fore and aft position, Driver's weight adjustable suspension type
Safety Belt	3 points lock type for driver and assistance seat 2 points lock type for middle seat

Chassis

Frame	Channel (C section), Ladder type
Side Member Main Section	250 x 80 x 8 mm. (Height x Width x Thickness) with reinforcement 234 x 72 x 6 mm.
Front Axle	Reverse Elliot I-Beam
Rear Axle	Fully floating banjo type, Tandem drive axles with DF lock
Suspensions	Front: Semi-elliptic leaf springs with shockabsorbers Rear: Trunnion mounted suspension with leaf springs and 6 rods

Registered Truck Model: CDA214MHRC
CDA214SHRC

Special Equipment: Wind Deflector and PTO are the standard equipment

Remarks: All details and pictures which shown in this leaflet may be option equipment and different from standard chassis. Nissan Diesel (Thailand) reserves the right to change any specification without notice.

Safety glass, 2 Layer,
Laminated type,
Sun filter coating



JOB BUILT-UP DURABLY & RELIABLY
Nissan Diesel (Thailand) Co., Ltd.

59 Moo 1, Rangsit-Pathumthani Road, Bangkok, Muang District, Pathumthani 12000

Tel: 0-2567-2882, 0-2567-2888, Fax: 0-2567-2883-4, 0-2567-2886-7 <http://www.nissandiesel.co.th>



2 years guarantee, unlimited distance
refer to our guarantee's condition



CDA 254 PS

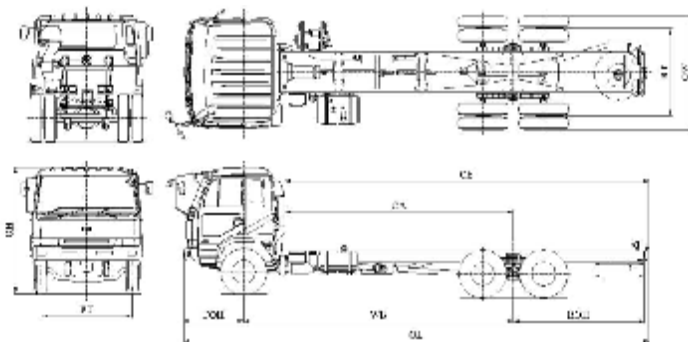

Performance	CDA214M	CDA214S
Maximum Speed (Km./Hr.)	114	114
Minimum Turning Radius (M.)	8.6	9.9
Gradeability (Tan θ)	0.256	0.256
at Gross Vehicle Weight (Kg.)	21,000	21,000

Weight	CDA214M	CDA214S
Chassis with cab (Kg.)	5,680	5,810
On front wheels (Kg.)	2,700	2,740
On rear wheels (Kg.)	2,980	3,070
Maximum GVW (Manufacturer)	22,000	22,000

General Dimension (MM.)

Model	WB	OL	OW	OH	FT	RT	CA	ROH	CE
CDA214M	4,800	8,380	2,435	2,685	1,940	1,860	3,925	2,200	6,125
CDA214S	5,750	9,930	2,435	2,685	1,940	1,860	4,875	2,800	7,675